



**⚠️ DANGER**

**HAZARD OF ELECTRIC SHOCK, EXPLOSION, OR ARC FLASH**

- Only appropriately trained persons who are familiar with and understand the contents of this manual and all other pertinent product documentation and who have received safety training to recognize and avoid hazards involved are authorized to work on and with this drive system. Installation, adjustment, repair, and maintenance must be performed by qualified personnel.
  - The system integrator is responsible for compliance with all local and national electrical code requirements as well as all other applicable regulations with respect to grounding of all equipment.
  - Many components of the product, including the printed circuit boards, operate with mains voltage. Do not touch. Use only electrically insulated tools.
  - Do not touch unshielded components or terminals with voltage present.
  - Motors can generate voltage when the shaft is rotated. Prior to performing any type of work on the drive system, block the motor shaft to prevent rotation.
  - AC voltage can couple voltage to unused conductors in the motor cable. Insulate both ends of unused conductors of the motor cable.
  - Do not short across the DC bus terminals or the DC bus capacitors or the braking resistor terminals.
  - Before performing work on the drive system:
    - Disconnect all power, including external control power that may be present.
    - Place a "Do Not Turn On" label on all power switches.
    - Lock all power switches in the open position.
    - Wait 15 minutes to allow the DC bus capacitors to discharge. The DC bus LED is not an indicator of the absence of DC bus voltage that can exceed 800 Vdc.
    - Measure the voltage on the DC bus between the DC bus terminals using a properly rated voltmeter to verify that the voltage is <42 Vdc.
    - If the DC bus capacitors do not discharge properly, contact your local Schneider Electric representative. Do not repair or operate the product.
  - Install and close all covers before applying voltage.
- Failure to follow these instructions will result in death or serious injury.**

Electrical equipment should be installed, operated, serviced, and maintained only by qualified personnel. No responsibility is assumed by Schneider Electric for any consequences arising out of the use of this product.

Information below is designed to use **single drive** connected to **single motor with a motor cable length less than 50 meters (164 ft)**. Verify your cables before connecting the drive with motor (length, power, shielded or unshielded)  
 For more information, consult the ATV12 user manual ([BBV28581](#)) on [www.schneider-electric.com](http://www.schneider-electric.com).

## 1 Verify the delivery of the drive

- Remove ATV12 from the packaging and verify that it has not been damaged.

**⚠️ WARNING**

**DAMAGED DRIVE EQUIPMENT**

Do not operate or install any drive or drive accessory that appears damaged.  
**Failure to follow these instructions can result in death, serious injury, or equipment damage.**

- Verify that the drive catalog number printed on the label is the same as that on the delivery note and corresponding purchase order.

Write the drive Model Reference: \_\_\_\_\_ and Serial Number: \_\_\_\_\_

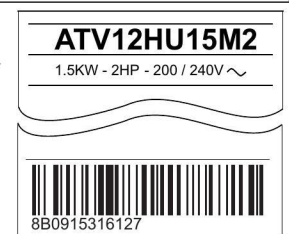

## 2 Verify the Supply Mains voltage compatibility

- Verify that the **Supply Mains voltage** is compatible with the supply range of the drive.  
 Supply Mains voltage \_\_\_\_\_ Volts      Drive voltage range \_\_\_\_\_ Volts  
 Drive range: ATV12●●●●●F1 = 100/120 V single phase / ATV12●●●●●M2=200/240 V single phase / ATV12●●●●●M3 = 200/240 V three-phase.

## 3 Mount the drive vertically

For a surrounding air temperature up to 40 °C (104 °F) or 50°C (122°F), based on product reference number.

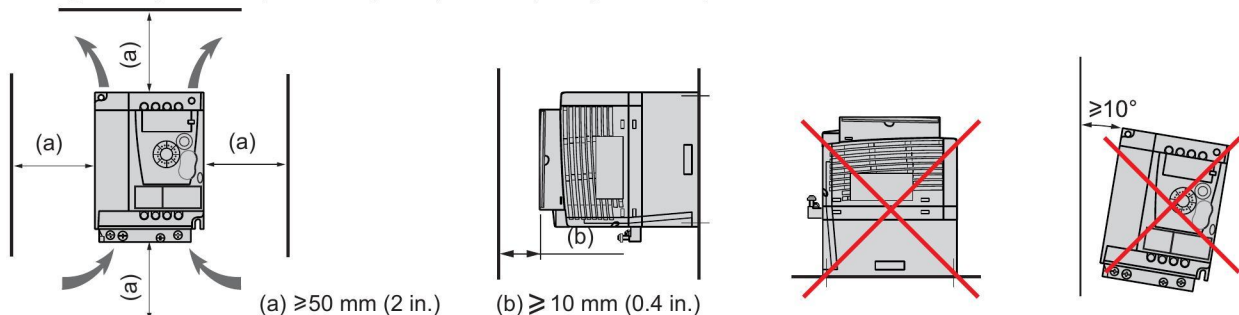

See user manual ([BBV28581](#)) on [www.schneider-electric.com](http://www.schneider-electric.com) for other thermal conditions.  
 For ATV12P baseplate product, see also the ATV12P installation manual ([BBV28587](#))

## 4 Connect power wiring

- Wire the drive to the ground.
- Verify circuit breaker rating or fuse rating.
- Verify that the motor voltage is compatible with the drive voltage.  
Motor voltage \_\_\_\_\_ Volts.
- Wire the drive to the motor.
- Wire the drive to the Supply Mains.

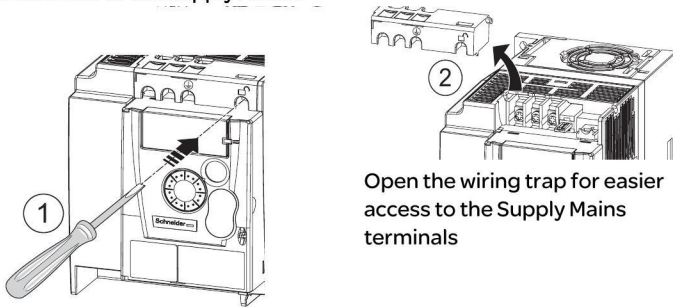

Open the wiring trap for easier access to the Supply Mains terminals

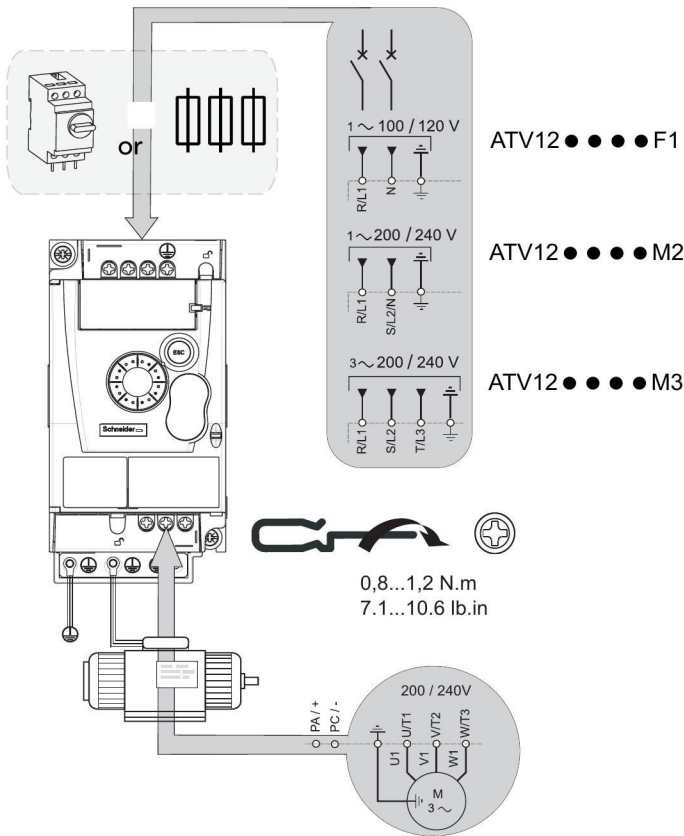

## 6 Apply power to the drive

- Ensure that Logic Inputs are not active (see Li1, Li2, Lix).
- Apply power to the drive.
- The drive displays **b F r** at first power up.
- On next start-ups, the drive displays **r d y**.

## 7 Set motor parameters

- Refer to the motor Nameplate for the following parameters settings.

Menu	Code	Description	Factory setting	Customer setting
<b>ConF &gt; FuLL &gt; drC -</b> [Motor control menu]	<b>b F r</b>	[Standard motor frequency]: Standard motor frequency (Hz)	<b>50.0</b>	
	<b>n P r</b>	[Rated mot. power]: Nominal motor power on motor nameplate	drive rating	
	<b>n C r</b>	[Rated mot. current]: Nominal motor current on motor nameplate (A)	drive rating	
<b>ConF &gt; FuLL &gt; FLt -&gt; tEt -</b> [Motor thermal protection menu]	<b>t Et</b>	[Motor thermal current]: Nominal motor current on motor nameplate (A)	drive rating	

## 5 Connect control wiring and Select control configuration

### 51 [REMOTE configuration] (Control by external reference)

- Open the door
- Wire the speed reference:

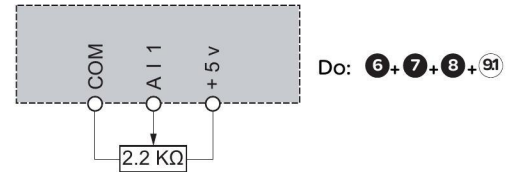

Do: 6+7+8+91

- Wire the command:  
Control command 2-wire:  
Parameter **t C C = 2 C**

L11: forward  
L1x: reverse

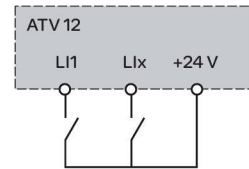

Do: 6+7+8+91

Control command 3-wire:  
Parameter **t C C = 3 C**

L11: stop  
L12: forward  
L1x: reverse

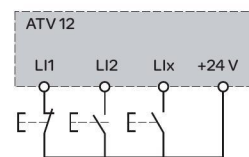

Do: 6+7+8+91

- Close the door

### 52 [LOCAL configuration] (control by internal reference).

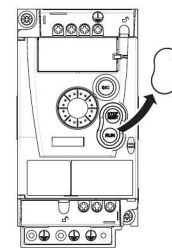

Do: 6+7+8+92

## 8 Set basic parameters

Menu	Code	Description	Factory setting	Customer setting
<i>ConF</i> [CONFIGURATION]	<i>ACC</i>	[Acceleration]: Acceleration time (s)	<i>3.0</i>	
	<i>DEC</i>	[Deceleration]: Deceleration time (s)	<i>3.0</i>	
	<i>LSP</i>	[Low speed]: Motor frequency at minimum reference (Hz)	<i>0.0</i>	
	<i>HSP</i>	[High speed]: Motor frequency at maximum reference (Hz)	<i>50.0</i>	

## 9 Set control choice

Menu	Code	Description	5.1 [REMOTE configuration]	5.2 [LOCAL configuration]	Customer Setting
<i>ConF &gt; FULL &gt; CTL -</i> [Control menu]	<i>Fri</i>	[Reference channel1]: Reference control	<i>AL1</i>	<i>ALu1</i>	
<i>ConF &gt; FULL &gt; &lt; I - O -</i> [Input Output menu]	<i>CCC</i>	[Type of control]: Command control	<i>2C</i> : 2-wire control <i>3C</i> : 3-wire control	-	

### 91 [REMOTE configuration] (configuration factory setting)

Parameters factory settings:

*Fri = AL1*  
*CCC = 2C*

### 92 [LOCAL configuration]

Parameters factory settings:

*Fri = ALu1*

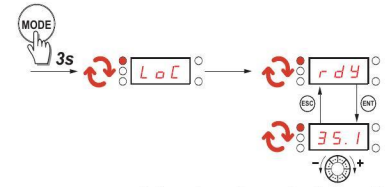

[Analog input virtual] (Hz)

## 10 Start the motor

## Troubleshooting

Code	Cause	Remedy
<i>SCF1</i>	Short-circuit or grounding at the drive output • Ground fault during running status	• Verify the cables connecting the drive to the motor, and the motor insulation
<i>SCF3</i>	• Commutation of motors during running status • Significant current leakage to ground if several motors are connected in parallel	• Connect motor chokes
<i>oBF</i>	• Braking too sudden or driving load too high	• Increase the deceleration time • Install a module unit with a braking resistor if necessary • Verify the Supply mains voltage, to be sure that it is under the maximum acceptable (20% over maximum supply mains during run status)
<i>oSF</i>	• Supply Mains voltage too high: - At drive power-on only, the supply is 10% over the maximum acceptable voltage level - Power with no run order, 20% over the maximum Supply Mains • Disturbed Supply Mains	• Turn Off the Drive. Verify and adjust the Supply mains voltage. • After Supply mains come back to nominal voltage (within tolerance) • Do power On. If intermittent <i>oSF</i> code appear, set Relay R1 to <i>FLt</i> and it can be connected to upstream protection to avoid overvoltage in the drive. In this case LO1 can be used. For others drive status see user manual
<i>oPF1</i>	• Loss of one phase at drive output	• Verify the connections from the drive to the motor • In case of using downstream contactor, verify the right connection, cable and contactor
<i>oPF2</i>	• Motor not connected • Motor power too low, below 6% of the drive nominal current • Output contactor open • Instantaneous instability in the motor current	• Verify the connections from the drive to the motor • Test on a low-power motor or without a motor: In factory settings mode, motor phase loss detection is active Output Phase loss detection <i>oPL = YES</i> . To verify the drive in a test or maintenance environment, without having to use a motor with the same rating as the drive, deactivate motor phase loss detection Output Phase loss detection <i>oPL = no</i> • Verify and optimize the following parameters: IR compensation (law U/F) <i>uFr</i> , Rated motor voltage <i>un5</i> and Rated motor current <i>nCr</i> and perform an Auto-tuning <i>tun</i> .
<i>uSF</i>	• Supply Mains too low • Transient voltage dip	Verify the voltage and the parameters of UndervoltagePhase Loss Menu <i>uSb-</i> .

# Menus structure

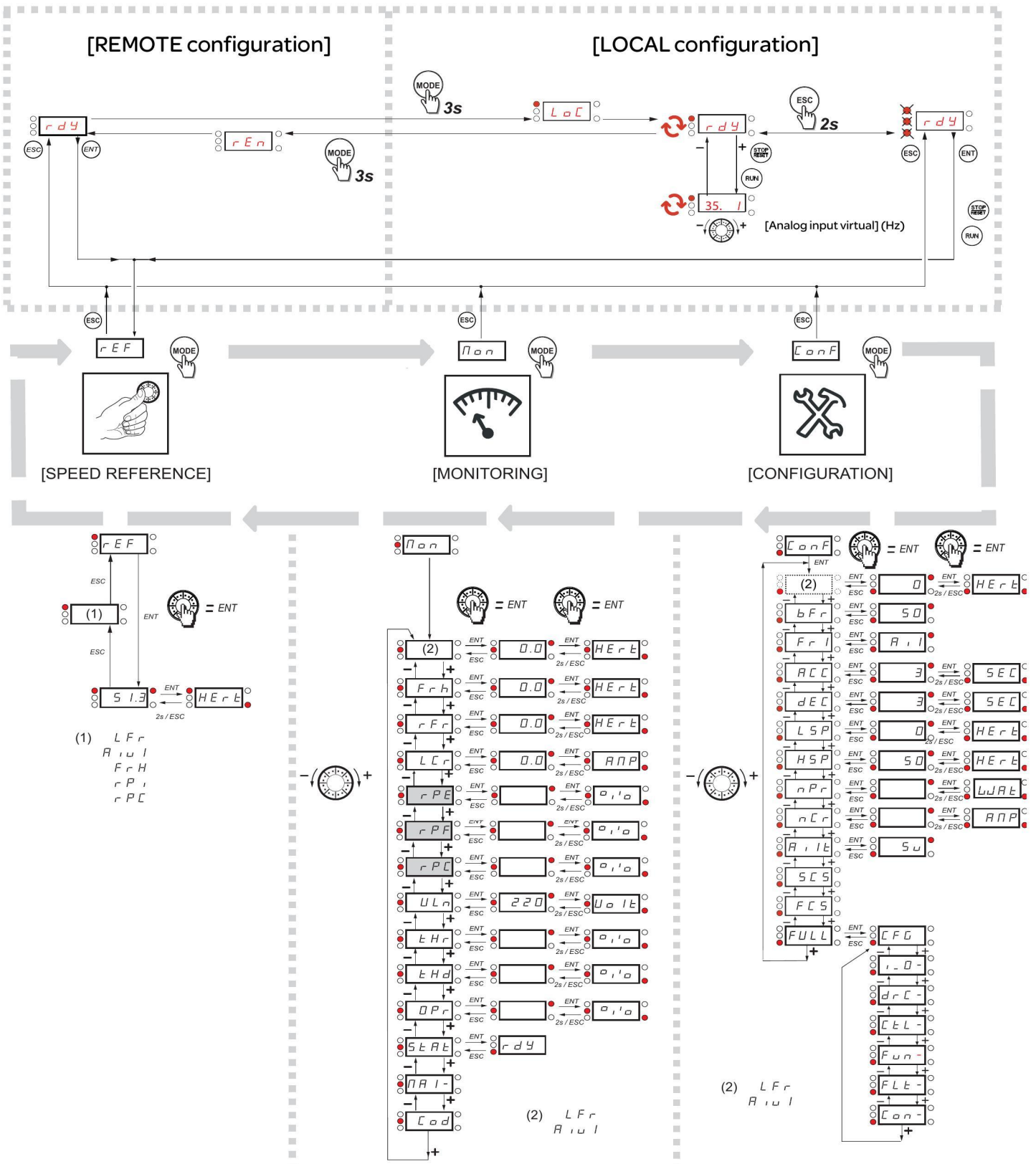

Refer to the ATV12 user manual ([BBV28581](#)) for comprehensive menu description and troubleshooting information.

A dash appears after menu codes to differentiate them from parameter codes.

Example: [Motor control menu] (*drC-*), *bFr* parameter.